

# 32111, 32115, 32116 - HD WHEEL CENTERING TOOLS

## Instruction Sheet

*This tool should only be used by personnel who have the necessary skill, training and tools to do the job correctly and safely. Incorrect installation can result in personal injury, vehicle damage and / or loss of vehicle control.*

1. Raise and support the vehicle on jackstands. Remove wheel assembly.
2. Remove any dirt, debris or corrosion from wheel studs and wheel mounting holes.
3. Install tools with tapered end away from hub (**Figure 1**). Install tools at 12, 4 and 8 o'clock positions (**Figure 2**).
4. Install wheel with centering tools in place.
5. Install wheel nuts and lightly tighten.
6. Remove centering tools and replace with the remaining nuts. Insert small screwdriver into cross-hole to pull out tool (**Figure 3**).
7. Tighten all nuts to wheel/stud manufacturer's specifications.

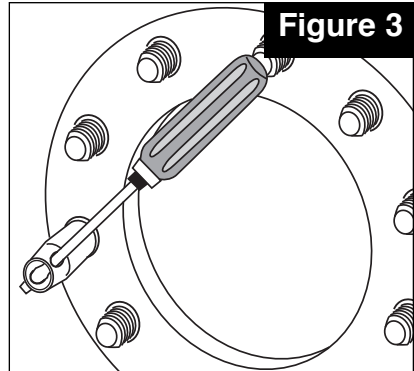
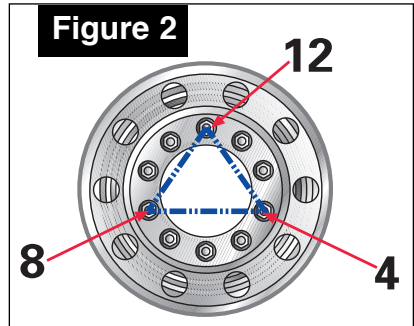
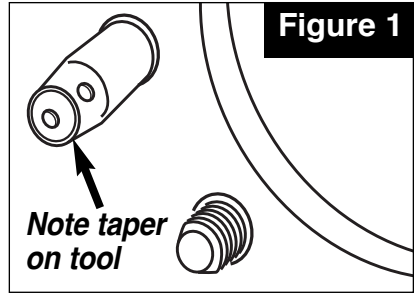

### Caution:

Always follow truck, tire and wheel manufacturer's recommended mounting and install procedures.

Do not force into wheel stud hole.

Do not use on Budd style wheels.

Remove Centering Tools tool before moving truck.

Part No.	Stud Size	Wheel Holes (min.)	Common Application
32111	22mm	26.5mm	Most OTR Wheels
32115	14mm	16.25mm	Ford F450/F550
32116	22mm	26.0mm	Alcoa Wheels made in Hungary



## Specialty Products Company®

P.O. Box 923 • Longmont, CO 80502 • (303) 772-2103 • Fax: (303) 772-1918  
 www.specprod.com • www.spcalignment.com • Email: info@specprod.com  
**Toll Free Technical Hot Line: 1-800-525-6505**

©2012 Niwot Corp. dba Specialty Products Co® • Printed in U.S.A. • Part No. 981111 • Rev. 7/12